

# CHAPTER 7 ■ SOLENOID EXPANSION VALVES

## FOR REFRIGERATION PLANTS THAT USE THE R744 REFRIGERANT



### APPLICATIONS

The solenoid expansion valves in series 2028E illustrated in this chapter have been developed by Castel for all the applications that use the sub-critical R744 refrigeration fluid belonging to Group 2, defined in Article 13, Chapter 1, Point (b) of Directive 2014/68/EU, with reference to EC Regulation No. 1272/2008.

**CAUTION!: the solenoid valves in this chapter cannot be used with other refrigerant fluids.**

### OPERATION

Please refer to Chapter 3, second paragraph, for the description of the operation of the valves in series 2028E, as it is identical to that of valves in series 2028.

### CONSTRUCTION

The valves in series 2028E are supplied complete with orifice. Ten different orifices with ten different maximum potentials that range from orifice 00 to orifice 09 can be assembled. The last two numbers in the part number identify the type of orifice that has been mounted on the valve at the factory. For example, part number 2028E/3S02 identifies a 3/8" valve with solder connections and size 02 orifice. The orifices are interchangeable and can be mounted even after the valve is soldered on the system. If you wish to change orifice, purchase the corresponding spare parts kit, according to the part number indicated in Table 38.

Valves in series 2028E are sold exclusively in the model without coil (suffix S).

The main parts of the valves in series 2028E are made from the same materials as the valves in series 2028, with the exception of:

- Ethylene propylene rubber (EPDM) for outlet seal gaskets

### SELECTION

Please refer to Chapter 3, paragraph 4, for the description of the operation of the valves in series 2028E, as it is identical to that of valves in series 2028.

### DIMENSIONING EXAMPLE

- Type of refrigerant: R744
- Evaporator capacity,  $Q_e$ : 2.8 kW
- Evaporating temperature,  $T_e$ : -30°C
- Minimum condensing temperature,  $T_c$ : -5°C
- Liquid refrigerant temperature,  $T_l$ : -15°C
- Pressure drop in the liquid line, distributor and evaporator,  $\Delta p$  2 bar

*Step 1 - Determine the pressure drop across the valve.*

- Condensing pressure at - 5 °C -  $P_c = 30.4$  bar
- Evaporating pressure at - 30 °C -  $P_e = 14.3$  bar

$$\Delta p_{tot} = 30,4 - (14,3 + 2) = 14,1 \cdot \text{bar}$$

*Step 2 - Determine required valve capacity*

$$\Delta T_{sub} = -5 - (-15) = 10 \cdot ^\circ\text{K}$$

From the subcooling correction factor Table 39B, we find the appropriate correction factor,  $F_{sub}$ , equal to 1.05 for  $\Delta T_{sub} = 10$  °K. The required valve capacity is

$$Q_{sub} = \frac{2,8}{1,05} = 2,67 \cdot \text{kW}$$

*Step 3 - Capacity correction based on the application*

According to the above sizing criterion, a correction of + 25% is applied to the calculated capacity:

$$Q_{ev} = 1,25 \cdot 2,67 = 3,33 \cdot \text{kW}$$

*Step 4 - Determine required orifice size.*

Using the capacity Table 39A for R744 refrigerant, enter the data:

- Pressure drop across the valve = 14.1 bar
- Evaporating temperature = - 30 °C
- Calculated evaporator capacity = 3.33 kW

Select the corresponding orifice, 02 (Note: the expansion valve capacity must be equal to or slightly greater than the calculated evaporator capacity).

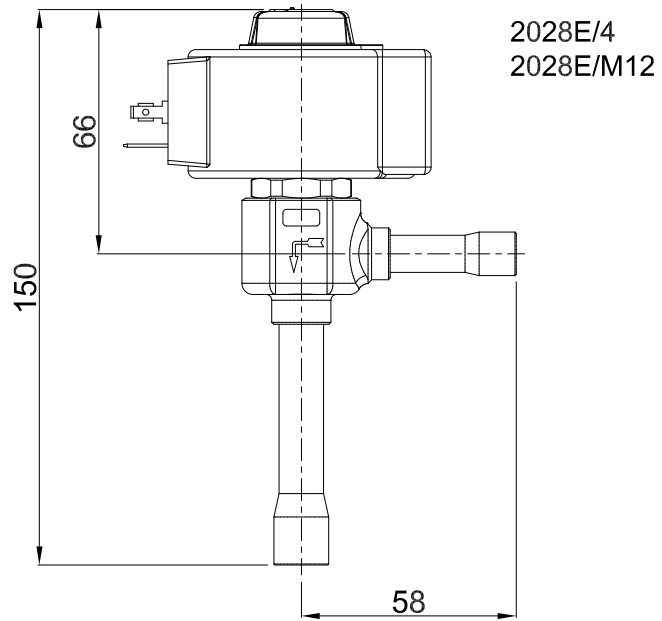
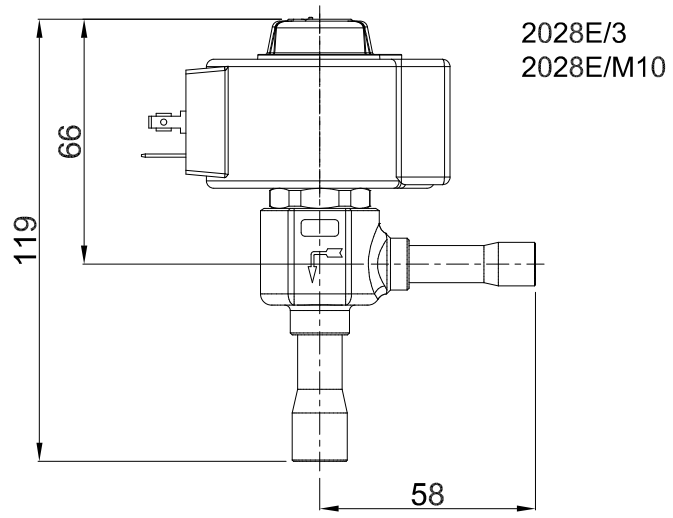

**TABLE 37: General characteristics of PWM expansion valves, suitable for R744**

Catalogue number	Orifice Type	ODS Connections				Kv Factor [m³/h]	Opening Pressure Differential [bar]			Operating principles	Minimum Working Time [s]	PS [bar]	TS [°C]		TA[°C]		Risk Category according to PED Recast
		[in]		[mm]			MinOPD	MOPD					min.	max.	min.	max.	
		IN	OUT	IN	OUT			9320 (AC)	9320 (DC)								
2028E/3S00	00	3/8"	1/2"	-	-	0	37	37	PWM (Pulse Width Modulating)	1	80	-50	+100	-40	+50	Art.4.3	
2028E/M10S00		-	-	10	12												
2028E/3S01	01	3/8"	1/2"	-	-												
2028E/M10S01		-	-	10	12												
2028E/3S02	02	3/8"	1/2"	-	-												
2028E/M10S02		-	-	10	12												
2028E/3S03	03	3/8"	1/2"	-	-												
2028E/M10S03		-	-	10	12												
2028E/3S04	04	3/8"	1/2"	-	-												
2028E/M10S04		-	-	10	12												
2028E/3S05	05	3/8"	1/2"	-	-												
2028E/M10S05		-	-	10	12												
2028E/3S06	06	3/8"	1/2"	-	-												
2028E/M10S06		-	-	10	12												
2028E/4S07	07	1/2"	5/8"	-	-												
2028E/M12S07		-	-	12	16												
2028E/4S08	08	1/2"	5/8"	-	-												
2028E/M12S08		-	-	12	16												
2028E/4S09	09	1/2"	5/8"	-	-												
2028E/M12S09		-	-	12	16												

**TABLE 38: Orifices - Rated capacities in kW**

Catalogue number	Orifice Type	Orifice Size [mm]	Refrigerant
			R744
9151E/R13	00	0,3	0,94
9150E/R63	01	0,5	2,30
9150E/R64	02	0,7	4,10
9150E/R65	03	0,8	5,40
9150E/R66	04	1,1	8,22
9150E/R67	05	1,3	14,50
9150E/R68	06	1,7	20,20
9150E/R69	07	2,3	32,10
9150E/R78	08	2,5	38,10
9150E/R79	09	2,7	43,40

Rated capacities are based on:

- Evaporating temperature  $T_{\text{evap}} = -25 \text{ °C}$
- Condensing temperature  $T_{\text{cond}} = 0 \text{ °C}$
- Refrigerant liquid temperature ahead of valve  $T_{\text{liq}} = -4 \text{ °C}$

**TABLE 39A: Refrigerant R744 - Capacities in kW**

Evaporating Temperature 5 °C														
Orifice Type	Pressure drop across valve [bar]													
	2	4	6	8	10	12	14	16	18	20	24	26	28	32
00	0,34	0,42	0,49	0,55	0,60	0,64	0,67	0,68	0,69	0,69	0,64	0,61	0,56	0,43
01	0,81	1,01	1,18	1,33	1,45	1,55	1,62	1,66	1,68	1,68	1,59	1,50	1,40	1,10
02	1,74	2,02	2,27	2,48	2,64	2,76	2,84	2,88	2,88	2,84	2,63	2,47	2,26	1,72
03	2,11	2,54	2,91	3,23	3,48	3,68	3,81	3,89	3,91	3,88	3,62	3,41	3,14	2,42
04	3,30	3,98	4,56	5,04	5,44	5,74	5,96	6,08	6,11	6,05	5,65	5,32	4,89	3,76
05	5,72	6,86	7,85	8,68	9,35	9,87	10,23	10,43	10,48	10,37	9,68	9,10	8,36	6,43
06	8,01	9,61	11,00	12,16	13,11	13,84	14,35	14,64	14,71	14,56	13,61	12,80	11,78	9,07
07	12,32	14,76	16,87	18,65	20,09	21,20	21,97	22,40	22,50	22,27	20,80	19,56	17,98	13,83
08	14,83	17,85	20,46	22,65	24,44	25,82	26,78	27,34	27,48	27,22	25,46	23,96	22,06	17,01
09	16,31	19,64	22,52	24,95	26,92	28,44	29,51	30,13	30,29	30,00	28,07	26,43	24,33	18,77
Evaporating Temperature 0 °C														
Orifice Type	Pressure drop across valve [bar]													
	2	4	6	8	10	12	14	16	18	20	24	26	28	32
00	0,36	0,45	0,53	0,60	0,65	0,69	0,72	0,74	0,75	0,74	0,70	0,66	0,60	0,46
01	0,89	1,11	1,30	1,47	1,60	1,71	1,78	1,83	1,86	1,85	1,75	1,66	1,54	1,22
02	1,91	2,22	2,49	2,72	2,90	3,03	3,12	3,17	3,17	3,12	2,89	2,71	2,48	1,89
03	2,24	2,70	3,10	3,43	3,70	3,91	4,05	4,14	4,16	4,12	3,85	3,63	3,34	2,57
04	3,46	4,17	4,77	5,28	5,70	6,02	6,24	6,37	6,40	6,34	5,92	5,57	5,12	3,94
05	6,12	7,34	8,39	9,28	10,00	10,55	10,94	11,15	11,20	11,09	10,35	9,73	8,95	6,87
06	8,31	9,97	11,41	12,62	13,60	14,36	14,88	15,18	15,26	15,10	14,11	13,28	12,22	9,41
07	13,37	16,02	18,31	20,24	21,80	23,00	23,84	24,31	24,42	24,16	22,57	21,22	19,51	15,01
08	15,96	19,21	22,01	24,38	26,30	27,78	28,82	29,42	29,58	29,29	27,40	25,79	23,74	18,31
09	17,69	21,30	24,43	27,06	29,20	30,85	32,01	32,68	32,86	32,55	30,45	28,66	26,39	20,36
Evaporating Temperature -10 °C														
Orifice Type	Pressure drop across valve [bar]													
	2	4	6	8	10	12	14	16	18	20	24	26	28	32
00	0,40	0,49	0,58	0,65	0,71	0,75	0,78	0,80	0,81	0,81	0,76	0,71	0,66	0,50
01	0,98	1,23	1,44	1,62	1,77	1,88	1,97	2,02	2,05	2,04	1,93	1,83	1,70	1,34
02	2,19	2,55	2,86	3,12	3,32	3,48	3,58	3,63	3,63	3,58	3,32	3,11	2,84	2,17
03	2,51	3,02	3,46	3,84	4,14	4,37	4,54	4,63	4,66	4,61	4,31	4,06	3,74	2,88
04	3,96	4,76	5,45	6,04	6,51	6,88	7,13	7,28	7,31	7,24	6,76	6,36	5,85	4,50
05	6,94	8,32	9,52	10,52	11,34	11,96	12,40	12,65	12,70	12,57	11,74	11,03	10,14	7,79
06	9,42	11,31	12,93	14,31	15,42	16,28	16,87	17,22	17,30	17,12	16,00	15,06	13,85	10,67
07	15,16	18,17	20,76	22,95	24,72	26,08	27,03	27,56	27,69	27,40	25,59	24,06	22,13	17,02
08	18,07	21,75	24,93	27,60	29,78	31,46	32,63	33,31	33,49	33,17	31,02	29,20	26,88	20,73
09	20,10	24,20	27,75	30,74	33,17	35,05	36,37	37,13	37,33	36,97	34,59	32,56	29,98	23,13
Evaporating Temperature -20 °C														
Orifice Type	Pressure drop across valve [bar]													
	2	4	6	8	10	12	14	16	18	20	24	26	28	32
00	0,48	0,56	0,63	0,70	0,76	0,81	0,85	0,89	0,91	0,93	0,95	0,94	0,93	0,88
01	1,19	1,39	1,58	1,75	1,89	2,02	2,12	2,21	2,28	2,32	2,35	2,34	2,30	2,18
02	2,60	2,89	3,14	3,37	3,57	3,73	3,86	3,96	4,03	4,07	4,05	4,00	3,91	3,65
03	3,01	3,43	3,81	4,14	4,44	4,68	4,89	5,05	5,17	5,24	5,27	5,21	5,11	4,79
04	4,74	5,41	6,00	6,53	6,99	7,38	7,71	7,96	8,16	8,28	8,33	8,25	8,11	7,61
05	8,32	9,45	10,47	11,38	12,17	12,84	13,40	13,84	14,16	14,37	14,44	14,30	14,04	13,18
06	11,29	12,84	14,23	15,46	16,53	17,45	18,21	18,80	19,24	19,53	19,61	19,42	19,07	17,89
07	18,16	20,63	22,84	24,80	26,51	27,96	29,16	30,11	30,81	31,25	31,38	31,07	30,50	28,61
08	21,67	24,70	27,42	29,83	31,94	33,73	35,22	36,40	37,27	37,83	38,04	37,68	37,01	34,75
09	24,10	27,48	30,52	33,22	35,57	37,57	39,24	40,56	41,53	42,16	42,39	41,99	41,24	38,72

Continued

**TABLE 39A: Refrigerant R744 - Capacities in kW**

Evaporating Temperature -30 °C														
Orifice Type	Pressure drop across valve [bar]													
	2	4	6	8	10	12	14	16	18	20	24	26	28	32
00	0,61	0,67	0,73	0,78	0,82	0,86	0,90	0,93	0,96	0,98	1,01	1,02	1,02	1,01
01	1,52	1,67	1,81	1,94	2,05	2,16	2,26	2,34	2,41	2,47	2,56	2,59	2,61	2,60
02	3,21	3,39	3,56	3,72	3,85	3,97	4,08	4,16	4,23	4,28	4,34	4,34	4,32	4,24
03	3,78	4,07	4,34	4,58	4,80	5,00	5,17	5,32	5,44	5,54	5,67	5,69	5,70	5,63
04	5,96	6,41	6,84	7,22	7,57	7,88	8,15	8,39	8,59	8,75	8,97	9,02	9,04	8,96
05	10,43	11,21	11,92	12,58	13,17	13,69	14,15	14,55	14,88	15,15	15,50	15,57	15,59	15,42
06	14,16	15,22	16,20	17,09	17,90	18,62	19,25	19,79	20,24	20,61	21,09	21,20	21,22	20,99
07	22,76	24,45	26,01	27,42	28,70	29,84	30,84	31,71	32,43	33,02	33,77	33,95	33,98	33,63
08	27,22	29,31	31,23	32,99	34,57	35,98	37,22	38,29	39,19	39,92	40,87	41,09	41,14	40,73
09	30,28	32,62	34,78	36,74	38,52	40,10	41,49	42,70	43,72	44,54	45,63	45,88	45,95	45,52

Evaporating Temperature -40 °C														
Orifice Type	Pressure drop across valve [bar]													
	2	4	6	8	10	12	14	16	18	20	24	26	28	32
00	0,71	0,76	0,81	0,85	0,89	0,93	0,96	0,99	1,02	1,04	1,08	1,09	1,10	1,12
01	1,77	1,89	2,01	2,11	2,21	2,30	2,39	2,46	2,53	2,59	2,69	2,72	2,75	2,78
02	3,65	3,79	3,92	4,03	4,14	4,24	4,32	4,39	4,45	4,51	4,57	4,59	4,59	4,57
03	4,35	4,58	4,79	4,99	5,17	5,33	5,48	5,60	5,72	5,81	5,95	6,00	6,02	6,03
04	6,85	7,21	7,54	7,85	8,13	8,38	8,61	8,81	8,99	9,13	9,35	9,42	9,46	9,47
05	11,98	12,59	13,15	13,67	14,15	14,58	14,96	15,29	15,59	15,83	16,19	16,30	16,36	16,35
06	16,27	17,10	17,87	18,58	19,23	19,81	20,34	20,80	21,19	21,53	22,01	22,16	22,24	22,23
07	26,14	27,46	28,68	29,80	30,83	31,75	32,58	33,30	33,93	34,46	35,22	35,45	35,58	35,54
08	31,30	32,95	34,47	35,87	37,15	38,31	39,35	40,26	41,06	41,73	42,71	43,01	43,20	43,21
09	34,84	36,68	38,38	39,95	41,39	42,68	43,84	44,87	45,76	46,51	47,61	47,96	48,16	48,18

Evaporating Temperature -50 °C														
Orifice Type	Pressure drop across valve [bar]													
	2	4	6	8	10	12	14	16	18	20	24	26	28	32
00	0,80	0,83	0,87	0,90	0,94	0,97	1,00	1,03	1,06	1,08	1,12	1,14	1,15	1,18
01	1,95	2,05	2,15	2,24	2,33	2,40	2,47	2,53	2,59	2,64	2,71	2,74	2,75	2,77
02	4,04	4,13	4,22	4,30	4,37	4,43	4,49	4,54	4,59	4,62	4,67	4,69	4,70	4,69
03	4,76	4,95	5,13	5,29	5,44	5,58	5,70	5,81	5,91	5,99	6,11	6,15	6,18	6,19
04	7,50	7,79	8,07	8,33	8,56	8,77	8,96	9,13	9,28	9,40	9,59	9,65	9,69	9,70
05	13,10	13,61	14,07	14,51	14,90	15,26	15,58	15,86	16,11	16,32	16,63	16,73	16,80	16,81
06	17,79	18,48	19,12	19,71	20,25	20,74	21,18	21,57	21,91	22,19	22,62	22,75	22,84	22,86
07	28,58	29,67	30,68	31,61	32,47	33,24	33,93	34,54	35,08	35,53	36,19	36,40	36,54	36,56
08	34,26	35,63	36,89	38,06	39,13	40,11	40,98	41,76	42,43	43,01	43,87	44,16	44,34	44,42
09	38,13	39,67	41,09	42,40	43,60	44,69	45,68	46,55	47,31	47,97	48,95	49,27	49,49	49,59

**TABLE: 39B - Correction factor for subcooling  $\Delta t_{sub} \neq 4^\circ K$**

$\Delta t_{sub} [^\circ K]$	1	4	10	15	20	25	30	35	40	45
$F_{sub}$	0,96	1,00	1,05	1,10	1,15	1,20	1,25	1,29	1,39	1,43

When subcooling ahead of the expansion valve is other than 4 °K , adjust the evaporator capacity by dividing by the appropriate correction factor found in Table 39B